



**THE MARK OF QUALITY SINCE 1902**

**OPERATOR'S INSTRUCTIONS AND PARTS LIST**

**MEADOWS MILLS, INC.  
1352 WEST D STREET  
PO BOX 1288  
NORTH WILKESBORO, NC 28659  
TOLL FREE: 1-800-626-2282  
TELEPHONE: 336-838-2282  
FAX: 336-667-6501  
EMAIL: [SALES@MEADOWSMILLS.COM](mailto:SALES@MEADOWSMILLS.COM)  
WEBSITE: [WWW.MEADOWSMILLS.COM](http://WWW.MEADOWSMILLS.COM)**

# **Operating Instructions for the Andrus Electric Saw**

## **Sharpener**

### **Unpacking your Andrus Saw Sharpener:**

- In reference to the band with bearing (Q), ensure that the nuts (H) holding the hex cap screws (G) are tight. If the band with bearing (Q) is tight this will ensure that the motor remains firmly in place.
- Using a flat head screwdriver and 7/16" wrench, advance the five adjustment screws (I) on the side of the filer frame (R) to an even depth of 1/4". Using your 7/16" wrench tighten nut (H) against the filer frame (R) while holding the screw (I) with your screwdriver.
- Ensure that the arbor (C) is firmly tightened against the washer (B). Next place the emery wheel (D) on the threaded shaft of the arbor (C), then place the washer (E) on the shaft, and finally finger tighten the nut (F) against the washer (E). The emery wheel (D) should be installed with the label facing the motor.
- Tighten the jam nut (F), which is found at the end of the arbor (C), firmly against the washer (E) to insure that the emery wheel (D) is held in place properly.
- The brass bearing (Q1) should be greased prior to operation. The zerk (Q2) can be found on the side of the band with bearing (Q).

### **Aligning your Andrus Saw Sharpener:**

- Place the saw sharpener on the saw so that the flat steel slide (S), located on the under side of the lip on the filer frame (R), rests on at least 2 teeth. The flat steel slide (S) should rest on at least 2 teeth for proper support and balance. The side block (Z) should be adjusted so that the side crank (AA) tightens on a shoulder of the saw. Tighten the side crank (AA) against the shoulder of the saw.
- Adjust the depth of the five adjustment screws (I) on the side of the filer frame (R) until the filer frame is level on the tooth. The filer frame must be level from side to side to ensure proper operation of the Andrus Saw Sharpener.
- Position the tooth stop (X), which is located under the wing nut (U) on the filer frame (R), so that the stop rests firmly against the base of the shank.
- Loosen the set screw on both of the set collars (P).
- Grasping the grip of the motor, slide the band with bearing (Q) up the shaft (N) until the emery wheel (D) is contacts the tooth. Hold the motor firmly against the tooth.

- Loosen the nut (J) that holds the eccentric (L), the eccentric frame (M), and the shaft (N) in place. This allows you to set the angle of the emery wheel (D) to match the face of your tooth. Once the angle is set tighten the nut (J) firmly. Continue to hold the motor against the tooth.
- The upper set collar (P) may be adjusted downwards until contact is made with the band with bearing (Q). This upper set collar (P) will act as an upper stop for the motor. Tighten the set screw in the upper set collar (P).
- Lower the motor to leave a 3/8" gap between the emery wheel (D) and the tooth. The bottom set collar (P), located under the band with bearing (Q), should be adjusted upwards until contact is made with the band with bearing (Q). This bottom set collar (P) will act as a lower stop for the motor. Tighten the set screw in the bottom set collar (P).
- As a final check for the setup of your Andrus Saw Sharpener, loosen the side crank (AA) and remove the Andrus Saw Sharpener from the saw. Using a pen/pencil (not provided) trace the profile of the tooth. Reposition the Andrus Saw Sharpener on the saw. Sharpen the tooth (see instructions "Operating your Andrus Saw Sharpener") that you used as your template. Compare the tooth you sharpened to your template to ensure that the filer is setup properly.

### **Operating your Andrus Saw Sharpener:**

- Once you have properly adjusted your Andrus Saw Sharpener to fit your saw, you are ready to file.
  1. Depress the trigger on the motor to start the emery wheel. Slowly pull the motor up the shaft (N) until the emery wheel (D) contacts the tooth. Please remember to bring emery wheel (D) into contact with the tooth slowly to ensure a clean evenly sharpened tooth.
- To move to the next tooth loosen the side crank (AA) and reposition your Andrus Saw Sharpener to the next tooth. Then follow the above instructions (1).

### **Please Remember**

- Lock out power supply to the saw arbor prior to setting up or operating the saw sharpener.
- As with all pieces of machinery safety glasses should be worn at all times. Also, at no point while the emery wheel is in motion should you attempt to touch the emery wheel with your fingers, hand, or any foreign object.
- The initial setup is more accurate if it is performed on a tooth with little or no wear.
- The Andrus Saw Sharpener should be setup perfectly square to ensure the best job of sharpening your teeth.

TOLERANCES ±1/16" UNLESS OTHERWISE SPECIFIED DIMENSIONS : FT--IN"

THIS DRAWING IS THE PROPERTY OF MEADOWS MILLS INC. USE OF THIS DRAWING OTHER THAN TO MANUFACTURE, SELL, OR INSTALL MEADOWS MILLS INC. EQUIPMENT IS PROHIBITED.



TITLE  
ANDRUS SAW FILE  
W/ ELEC. MOTOR DRIVE  
PARTS LIST

SCALE: N/A DATE: 10/10/01  
SAP FILE NAME: ANDRPART01 DRAWN BY: DLT

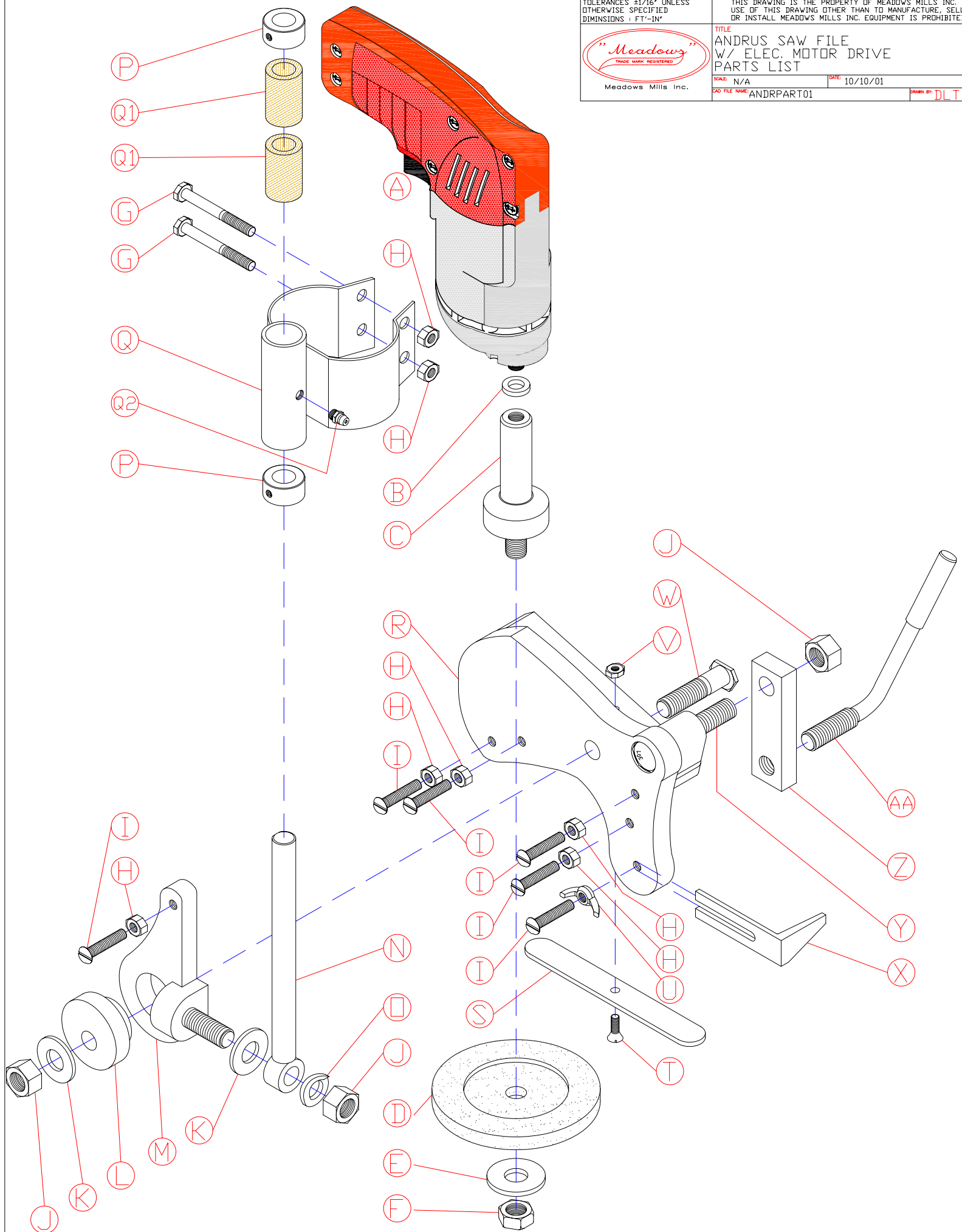

# ANDRUS ELECTRIC SHARPENER COMPLETE

## 65-1022 ANDRUS ELECTRIC SHARPENER COMPLETE

ITEM	QTY.	PART#	DESCRIPTION
A	1	65-1025	MOTOR - ELECTRIC FILER

## 65-1022 ANDRUS ELECTRIC SHARPENER W/ ARBOR - LESS MOTOR

ITEM	QTY.	PART#	DESCRIPTION
B	1	65-1052A	WASHER - AIR & ELEC. MOTOR (45-88-7940
C	1	65-1036	ARBOR - ELECTRIC & AIR FILER
D	1	65-1035	EMORY WHEEL - ELECTRIC & AIR FILERS
E	1	93-33087	SAE FLAT WASHER 9/16" PLN
F	1	93-36210	HEX JAM NUT 1/2" Z
G	2	93-13012	HCS 1/4"-20 x 2-1/4" Z 5
H	7	93-36102	FIN HEX NUT 1/4-20 Z
I	6	93-27696	RND. HEAD SLOTTED MS 1/4-20 x 1-1/4"
J	3	93-36110	FIN HEX NUT 1/2"-13 Z
K	2	93-33012	USS FLAT WASHER 1/2" Z
L	1	65-1034	ECCENTRIC - ELEC. & AIR FILERS
M	1	65-1029	ECCENTRIC FRAME - ELEC. & AIR FILERS

N	1	65-1028	SLIDE W/ LOCKING COLLARS (INCLUDES PART P)	
	ITEM	QTY.	PART#	DESCRIPTION
*	P	2	80-9915	SET COLLAR 9/16" W/ SET SCREW

O	1	93-33626	L/W Z 1/2"
---	---	----------	------------

Q	1	65-1026	BAND & BEARING - ELEC. SHARPENER , INCLUDES PARTS Q1 & Q2	
	ITEM	QTY.	PART#	DESCRIPTION
*	Q1	2	80-9886BC	BRONZOIL BUSHING OIL IMPREGNATED
*	Q2	1	93-60105	ZERK 1/4-28 STR

R	1	65-1030	MAIN FRAME FOR ELEC. & AIR FILERS
S	1	65-1017	FLAT STEELE SLIDE - ELEC., AIR, & HAND FILERS
T	1	93-27969	FLAT HEAD SLOTTED MS 10-24 x 5/8" Z
U	1	93-37745	WING NUT 1/4-20
V	1	93-36028	MS NUT 10-24 Z
W	1	65-1039	ECCENTRIC BOLT - ELEC. & AIR FILERS
X	1	65-1033	STOP - ELEC. & AIR FILERS
Y	1	93-13213	HCS 1/2-13 x 2-1/2" Z 5
Z	1	65-1006	SIDE BLOCK - ELEC., AIR, & HAND FILERS
AA	1	65-1007	SIDE CRANK - ELEC. & AIR FILERS

REFERENCE DWG. ANDRPART01 - ITEM #'S WILL CORRESPOND WITH THE DRAWING
--

# Andrus Saw Sharpeners

Manufactured by Meadows Mills, Inc.

Meadows Mills Inc. has combined its nearly 100 years of expertise in manufacturing sawmill equipment with Apex Manufacturing and its nearly 50 years of expertise in manufacturing saw sharpeners to present the Andrus saw sharpener in our continuing effort to be your complete supplier for sawmill equipment.

Andrus saw sharpeners are designed to sharpen the teeth of any inserted tooth saw. An optional diamond wheel is available to sharpen inserted carbide teeth.

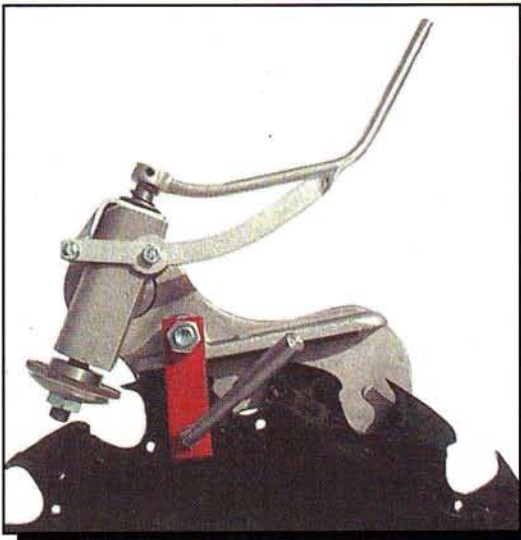

*Andrus Hand Filer*

## **Andrus Rotary Hand Filer**

\$ \_\_\_\_\_

- Alloy frame allows for lightweight yet sturdy construction
- Standard construction is right hand, also available in left-hand models
- Simply loosening the side crank moves the filer from tooth to tooth
- Tension on the tooth is provided by a thumb lever
- Weight is only 6 lbs.
- Price includes 1 file set for sharpening standard steel teeth
- Diamond wheel is available for rotary hand filer

## **Andrus Electric Saw Sharpener**

- Sharpener uses a Milwaukee 4 amp, 120 volt/60 hertz, 0-2500-rpm motor
- Also available without motor
- Price includes one 4" emory wheel with 1/2" bore for sharpening standard steel teeth
- Weight is only 9 lbs.

\$ \_\_\_\_\_



*Andrus Electric Saw Sharpener*



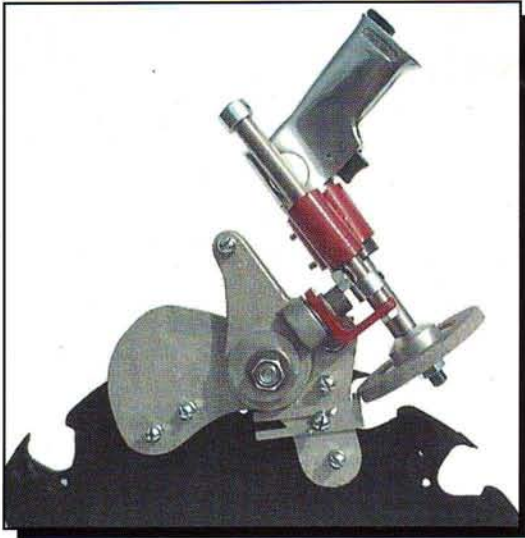

*Andrus Air Saw Sharpener*

## **Andrus Air Saw Sharpener**

- Uses Northman Industrial Tool 3/8" air drill, 2500-rpm, requires 4 CFM with 3/8" minimum hose diameter
- Also available without motor
- Price includes one 4" emory wheel with 1/2" bore for sharpening standard steel teeth
- Weight is only 8 lbs.

\$ \_\_\_\_\_

## **Andrus Electric Bank Saw Sharpener**

- Also available with air motor or available without motors
- Uses same electric and air motors as specified for previous saw sharpeners
- Hand clamps allow for ease in sharpening banks of saws where side crank cannot be used
- Price includes one 4" emory wheel with 1/2" bore for sharpening standard steel teeth
- Weight for electric bank saw sharpener is only 11 lbs.
- Weight for air bank saw sharpener is only 10 lbs.

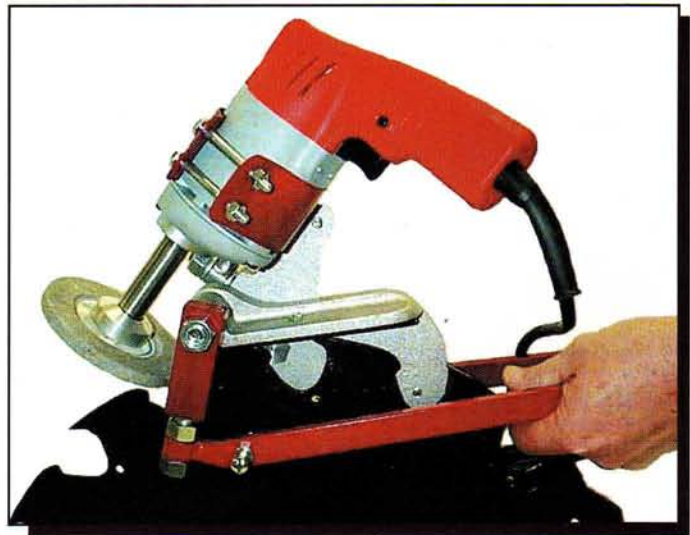

*Andrus Electric Bank Saw Sharpener*

\$ \_\_\_\_\_

## **Meadows Mills, Inc.**

*"Mill Manufacturers since 1902"*

1352 West D Street • Post Office Box 1288 • North Wilkesboro, North Carolina 28659  
Phone: (336) 838-2282 • Fax: (336) 667-6501 • 1-800-626-2282

